

swissonic



Portable Digital Audio Recorder

High quality portable digital audio recorder, specially designed for audio and music recording.

User's Guide

swissonic

1. Introduction	4
2. Notice	5
3. Parts description (Switches, Connectors, and Buttons)	5
4. Power on	8
5. Operate MENU setup	8
6. Recording	9
7. Playback	12
8. Delete tracks	13
9. Transfer to and from your computer	13
10. Specification	15

1. Introduction

Thank you for purchasing the Swissonic MDR-2 Portable Digital Audio Recorder. This machine is equipped with leading edge digital recording technology, excellent sound quality and easy operation, is suitable for acoustic instruments, electric guitars, microphones, keyboards, MP3 players, interviews, education, band rehearsal, ecological records...and more.

Features of MDR-2

9 Groups and 99 Recording Tracks

The MDR-2 provides 1-9 groups, numbered 1-9, and 99 recording tracks for each group, for either the internal flash memory or SD card. You may select any blank track number you prefer to record on before you record, or the MDR-2 will select a blank track for you automatically. Whenever a track is recorded, the track number will be fixed and you will not be able to change it even if the previous track is deleted or added. There is no limit in recording time for each individual recording track.

Two Storage Folders

The MDR-2 provides two folders for storage files: in FOLDER 1, you can record music either from the built-in microphone, from an external microphone, from an electric guitar and from Line-in sources and play it back. In FOLDER 2, you can download MP3 music from your PC or MAC and play it. The two flexible operation folders allow flexibility to organize your music for both your recording and leisure time.

Leading and Unique Sound Mixer Technology

The Swissonic MDR-2 is equipped with built-in microphones, and two audio inputs. When you connect audio inputs to record, the sound will automatically be mixed with the built-in microphone with a balance level. Our leading and unique sound mixing technology is perfect for occasions with multiple instruments playing, combinations with background music or for the creation of any creative music made by you!

Multiple Audio Inputs Selection

The MDR-2 is equipped with two Audio-in jacks for Left & Right channel recording. You can select to plug in external microphone, electric guitar, or Line-in as recording sources, by changing the switch position of the *Audio-in selector*. The multiple audio input selection adds more convenience to your recording experience!

2. Notice

Please read the following notice before you use the MDR-2.

1. Please read this guide carefully before you use the device.
2. Please notice the position to put batteries inside the MDR-2
3. Please use the DC power adaptor of USB type in correct 5V DC specification.
4. Please do not take apart or repair the MDR-2 by yourself. Please bring the MDR-2 back to your retailer or to a local service vendor for repair and assistance.
5. In order to keep stable data transmission, please do not twist the USB cable when you plug it into the computer.
6. The built-in LCD display is a fragile electronic part, please do not press on it heavily and do not touch it with sharp objects. We suggest you use only special cloth to clean the LCD display. Please make sure that the LCD display does not get exposed to water.
7. The SD card is a very precise electronic device, please use it according to the following notice: Prevent taking the SD card out of the machine during data transmission. Do not bend, strike, drop or take apart the SD card. Prevent to place the SD card in a place with high temperature, high humidity or dust. Do not expose the SD card to static electricity. In addition:
 - Please make sure the SD card you are using has been formatted (the format type of the MDR-2 is FAT32).
 - Please release the write protection switch of SD card before you record.
 - The MDR-2 processes large amount of data during recording and playback, as result, we strongly suggest you to use high speed SD cards as extension memory only, to prevent noise, data lost or any transmission problem.

We do not guarantee the function, operation or life of any SD card that is used in the device. We do not also take any responsibility of indemnity for the damage of SD cards. Like any digitally stored data, data shall be backed up regularly. In no event, we will be liable to any indirect incidental, special or consequential damages to any person caused by, or for any lost profits, lost savings, loss of use, loss revenues or lost data arising from or relating to this device.

3. Parts Description (Switches, Connectors, and Buttons).

Switches and connectors on the MDR-2

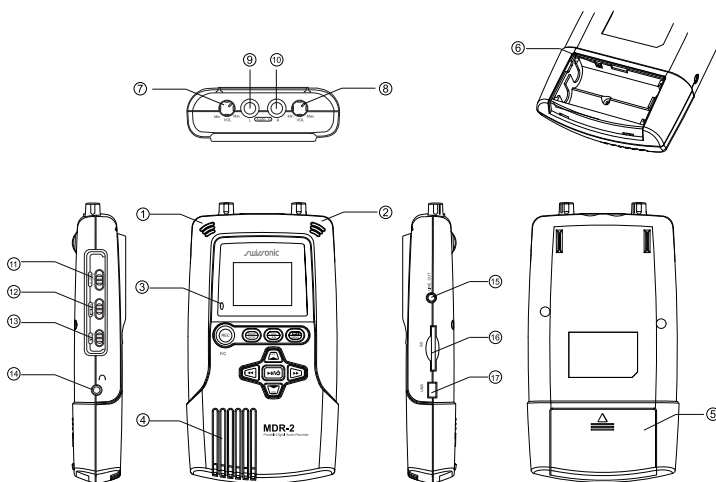

1. *Built-in microphone "L" channel:* an omni condenser microphone is installed into the device as "L" channel.
2. *Built-in microphone "R" channel:* an omni condenser microphone is installed into the device as "R" channel.
3. *Recording indicator LED:* the LED will light up during recording.
4. *Built-in speaker:* a monitor speaker is installed, it will stop working when earphone is plug in.
5. *Battery cover:* open the cover and install two AA batteries to work.
6. *Battery select switch:* when using primary batteries (or Alkaline batteries), switch to "1.5V"; or switch to "1.2V" when using Ni-MH rechargeable batteries.
7. *Volume controller of Audio-in "L" channel.*
8. *Volume controller of Audio-in "R" channel*
9. *Audio-in "L" channel:* it allows audio input of M(ext. microphone), G(E. guitar) or L(Line-in). It provides 1.5V power supply.
10. *Audio-in "R" channel:* it allows audio inputs of M(ext. microphone), G(E. guitar) or L(Line-in). It provides 1.5V power supply.
11. *Audio-in selector:* to select three kinds of audio input types, M(ext. microphone) / G(E. guitar) / L(line-in)

12. *Built-in microphone sensitivity selector:* H(high) / L(low) / OFF: to select the sensitivity level of built-in microphones, H(high) or L(low). Or switch off the built-in microphone (OFF).
13. *Key hold switch ON / OFF:* switch “ON” to hold (stop running) the key control, or switch “OFF” to release key control.
14. *Earphone jack (stereo):* when an earphone is connected to this jack, the built-in speaker will be switched off.
15. *Line out port:* connect to amplifier.
16. *SD card socket:* allow to use install SD memory cards.
17. *USB socket / DC Power in:* Use a USB cable to connecting with a computer. You may use USB type DC adaptor (DC 5V) to work from this port (DC power adaptor is not include).

Button control



Record button: press the button to start recording



Stop button: press the button to stop or cancel operations (recording, playback, delete...)



A-B loop button: press the button during playback to define a loop start point (A point), then press the button again to indicate the loop end point (B point). The music will then play from A to B again and again loop until you press the button again to stop.



MENU button: press the key to enter MENU, press the button again to leave MENU.



Power/Play button: press still for 2 seconds to switch ON or OFF the machine; Press the button to PLAYBACK; press it during playback will pause playback, push it again to continue playback.



Track down/Rewind button: Press the button once to select previous track, hold down the button to change the track number quickly; Hold down the key during playing to rewind playback, release the button to go back to normal playback.



Track up/Forward key: Press the button once to select next track, hold down the button to change the track number quickly; Hold down the key during playing to fast forward playback, release the button to go back to normal playback.



Vol. up/ Manual selector button: Press the button during playback to increase the volume level of earphone or speaker; Press this button for item selection when in MENU mode.



Vol. down/ Manual selector key: Press the key while playing to decrease the volume level of earphone or speaker; Press the key for item selection in MENU mode.

MODE button control

The MODE button is used to provide additional functions. To operate a MODE function, press the MODE button first (the LCD will show MODE) and then press the desired function button immediately to operate the MODE function. Here is a description of the mode functions:



Memory selection: use this function to select the internal flash memory or the SD card memory as record target and playback source.



Delete tracks function



Folder 1 or Folder 2 select mode function





Group number: decrease the selection function









Group number: increase the selection function

4. Power on

1. Open the battery cover and install two new AA batteries into the MDR-2.
2. The MDR-2 works on both primary batteries (and Alkaline batteries) and Ni-MH rechargeable batteries. To use primary batteries, select to “1.5V” position; to use Ni-MH rechargeable batteries, select to “1.2V” position of the battery select switch.
3. Hold the  button still for two seconds, the device will switch on and enter the operating mode.
4. Press the button still for two seconds to switch off the device.
5. The device will switch off automatically if there is not any other button control after 5 minutes.
6. The LCD will show “” when the batteries are at low power level, please change new batteries at this point.

5. Operate MENU setup

When press  key, the LCD will show up all main items of MENU setup, press  or  keys to move to previous or next main items, press  or  keys to interchange to secondary items. Press  key again to leave MENU mode.

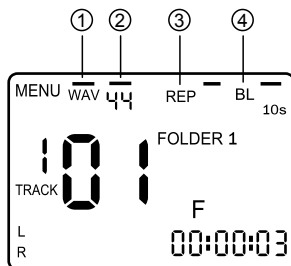

1. *Recording format* : There are two formats available for recording, WAV and MP3.
2. *Sample rate*: For WAV format, there are 6 sample rates to select: 8KHz, 11KHz, 16KHz, 22KHz, 32KHz, 44KHz.
For MP3 format, there is only one sample rate: 44KHz
3. *REP(repeat)*: there are two repeat functions, REPEAT (the track will be repeated always) or REP All (the device will repeat all the tracks). The LCD will show nothing if user does not select REP function.
4. *BL(back light time)*: There are four back light time for selection
 - ON (back light always on)
 - 10s (turn the back light off if there is not any other button control after 10 sec)
 - 20s (turn the back light off if there is not any other button control after 20 seconds)
 - OFF (no back light)

6. Recording

How to record

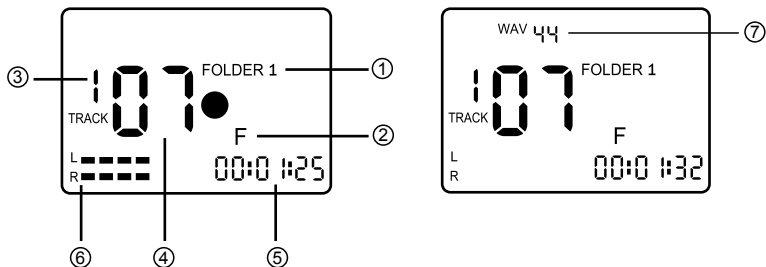

1. The device allows you to record ONLY in FOLDER 1. To change to FOLDER 1, press **MODE STOP** + **MENU**, when the LCD display shows FOLDER 1, you are in FOLDER 1 mode. (1)
2. The device allows you to record into the internal flash memory or into an installed SD card memory (2). The MDR-2 will change to the SD card memory automatically when SD card is installed. Or you can press **MODE STOP** + **REC** to interchange between the memory of the internal flash memory (F) and the SD card. (C)
3. Press **MODE STOP** + **◀** or **MODE STOP** + **▶** to select the group number in the range from range 1 to 9. (3)
4. Press **◀** or **▶** to select the recording track in the range from 01 to 99 to record (4). You may select any of a blank track number you want to record to, then press **REC** button to record; Or just press **REC** button directly, the device will select a blank track follows the last recorded track number to record (for example, if the last recorded track number is 05, the automatically selected track number will be 06).
5. Press **REC** button to start recording, the *Recording indicator LED* will light up still, the LCD display will show "●" and the time clock will start running (5), which means that the recording is in progress. Press **⏸** to pause record during recording, the *Recording indicator LED* will start flash, press the same button again to continue recording. Press **MODE STOP** button to finish recording.
6. The volume indicator will show on the LCD during recording (6), you can adjust input volume by the *Volume controller of Audio-in* (8 or 9). Please do not set to the highest volume level on recording, otherwise, the recording sound quality will be distorted.

- When you finish recording, the recording format and sample rate of this track will show up on the LCD. (⑦)
- For long time recording, you can switch *Key hold switch* (⑭) to ON position to hold (stop running) the key control. And switch to OFF position to release key control.

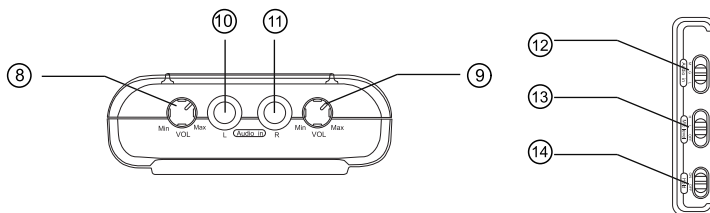

Record from microphones

- The MDR-2 is equipped with two built-in microphones (omni directional condenser type). You may adjust high/low sensitivity level of built-in microphones for recording from the *Built-in microphone sensitivity selector* (⑬). The high sensitivity level of built-in microphone is at -45dB(at 1KHz), while the low sensitivity level is at -35dB(at 1KHz). You may also adjust the *Volume controller of Audio-in* to make slight volume adjustment. (⑧ or ⑨).
- There are two extension *Audio-in jacks* of MDR-2 (⑩ & ⑪). They allow you to plug two extension microphones into the jacks for recording, please select to "M" position of the *Audio-in selector* (⑫). The two Audio-in jacks both provide DC 1.5V power, you may use either condenser microphones or dynamic microphones as recording sources. The extension microphone record level is adjustable via the knob of *Volume controller of Audio-in* jack (⑧ or ⑨) for proper recording sound level.
- The recording source of the built-in microphones and the extension microphones will be mixed into two separate tracks (Left and Right channels) with balance level.
- You may turn off the built-in microphones while recording from other sources. Switch to OFF position from the *Built-in microphone sensitivity selector*. (⑬)

Record from electric guitar or line-in

1. The MDR-2 allows you to plug in an electric guitar as recording source. Please select to "G" of the *Audio-in selector* (12). The electric guitar record level is adjustable via the knob of *Volume controller of Audio-in jack* (8 or 9) for proper recording sound level.
2. The MDR-2 allows you to plug line-in as recording source, such as CD players, tape decks, radios, etc. Please select to "L" of the *Audio-in selector* (12). The line-in record level is adjustable via the knob of *volume controller of Audio-in jack* (8 or 9) for proper recording sound level.
3. The recording source of the built-in microphones and the electric guitar or line-in recording source will be mixed into two separate tracks (Left and Right channels) with balance level.
4. You may turn off the built-in microphones while recording from other sources. Switch to OFF position from the *Built-in microphone sensitivity selector* (13)

Suitable position to record

1. Polar pattern of the built-in microphones The built-in microphone of MDR-2 is of omni-directional condenser microphone type. The sound collecting area is wide as below diagram.

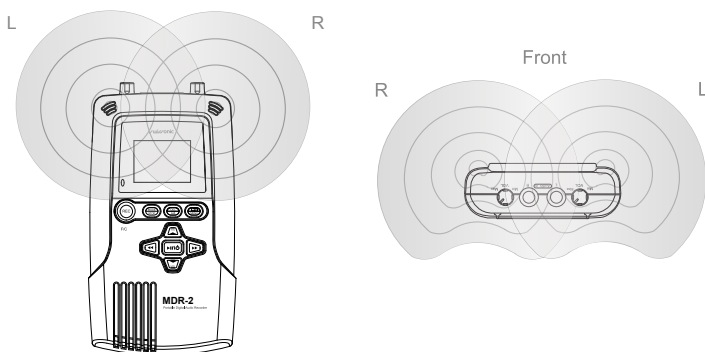





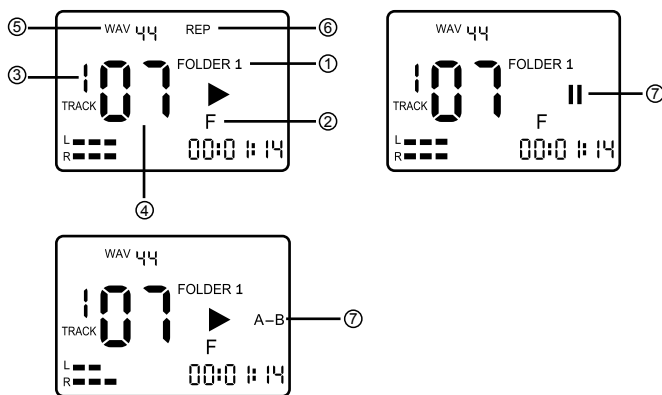





- To produce best recording result, we suggest that you put the MDR-2 at a distance of around 60cm from the sound source, at table height.
- Please adjust the input volume level to a proper condition. Do not set to the highest volume level on recording, otherwise, the recording sound quality will be distorted.
- In situations where multiple instruments are played simultaneously, the MDR-2 should be positioned near to instruments with smaller sound levels – or you need to use extension microphones for the different instruments.
- If you want to record speech (e.g. from a teacher) together with the playing of instruments, it is best if the speaker uses the extensional lapel microphone to improve the results.
- For better recording quality, the extensional lapel microphone could also be clipped on score stands or the body of a player, depending on the situation.



7. Playback



- FOLDER 1 or FOLDER 2:** You need to enter the FOLDER 1 to play the files/tracks previously recorded with the MDR-2. Enter the FOLDER 2 instead to play files downloaded/transferred from a computer. To change between the two folders, you need to press **MODE/STOP** + **ENTER/MENU** to interchange FOLDER 1 and FOLDER 2. (①)
- Playback from flash memory or SD card memory:** Select the files you want to playback from internal flash memory or SD card memory (further explained in the previous chapter Recording) (②)

3. *Select the Group and track you want to playback:* By pressing  +  or  to select group number in the range from 1 to 9. (③)
And select the track to playback by press  or  button in the range from 1-99(④). The recording format and sample rate of the track you select will show up on the LCD display. (⑤)
4. Press  to start to playback, the LCD display will show “▶”. Press the button during playing to pause, the LCD display will show “||” and flash. Press the same button again to continue playing.
5. *Forward and rewind during playback:* Hold on  during playback to rewind the playing. Hold down  to forward the playing. The time display will move quickly according to the position. Release the button to go back to normal playback.
6. *Repeat and Repeat All:* Enter the MENU mode, and set up repeat mode. When select REP, the track will be repeated always. If you select REP All, the device will repeat all the tracks. Please note that the REP All function only works in FOLDER 2 mode. The LCD will show REP mode on the LCD display. (⑥)
7. *A-B loop :* press  button during playback to define a loop start point (A point), then press the button again to indicate the loop end point (B point). The music will then play from A to B again and again loop until you press the button again to stop. (⑦)
8. The device allows you to adjust the volume level of earphone or built-in speaker by press  or  during playback. The adjusting level range is from 00 to 20.

8. Delete tracks



You can delete the recording files via computer or by the device itself. The following progress is the way to delete the files with the device: Select the track you want to delete, press  + , the LCD will show “dEL”, then you need to press  again, the machine will start to delete the track. When the LCD finish showing “DELETE” and the clock return to 00:00:00, means the track is empty and are available for a new recording.

9. Transfer to and from your computer

The device can be connected with computer, to copy and store your recording files on your computer (to backup your data), or download music to play at this unit.

When you connect USB port with your computer, the computer will detect the MDR-2 as two removable disks (the first disk represents the built-in flash memory; the second disk represents the SD card memory), and you will find folders of Group 1 – 9 in each removable disks. The music you have downloaded from the computer to the device will be accessible in FOLDER 2, and the track number depends on the sequence in which the files are transferred. This means that the track number in FOLDER 2 is not fixed and can be changed at any time if a track is deleted or added. If you want the files get a fixed track number, you can store the music in FOLDER 1. To do this, you simply need to change the filenames according to the following sequence:

- a) If you want to download files to FOLDER 1 to be with fixed track number, and store to the built-in flash memory, change the file name to M_INT_xx (where xx is the track number you want it to be.)
- b) If you want to download files to FOLDER 1 to be with fixed track number, and store to the SD memory card, change the file name to M_EXT_xx (where xx is the track number you want it to be.)

The device can work with USB adaptor, when connecting with computer, press  once, the machine will enter the operating mode, then you can operate the device with the power of computer. You will leave the operating mode when you press  over 2 seconds.

10. Specifications

Recording media: Internal flash memory 128MB, SD memory card (16MB - 2GB), SDHC memory card (4GB)

SD card format type: FAT 32

Recording format: WAV(16bit), sample rate:8/11/16/22/32/44.1KHz;

MP3(128Kbps), sample rate: 44.1KHz.

Playback format: WAV: PCM WAV with sampling rate of 8KHz, 16KHz, 32KHz and 44.1KHz,

MP3: MPEG1,MPEG2,MPEG2.5 Layer3, from 32K~320Kbps

S/N ratio at 1KHz: 55dB

Frequency response: 20 – 20KHz

Built-in microphone: omni-directional condenser microphone type

Input: two 1/4" mono for selection of extension microphone, Line-in, and E. Guitar (plug-in power 1.5V)
Built-in stereo microphones(L & R).

Output: 1/8" stereo headphone

1/8" stereo Line out

Built-in speaker: 0.2Watt, 8 Ohm

USB interface: Mini-B type (USB 2.0 Full-Speed compatible)

Power requirements: AA battery x 2, or USB DC adaptor 5V (not included).

Battery life

(Alkaline batteries): 5 hours for recording, or 6 hours for playback (by earphone)

Dimensions: 15.5(L) x 8.5(W) x 3(D) cm

Weight: 200g (not include batteries)

Accessories: Two lapel microphones, USB cable, two AA batteries, and a headphone.

